



Regulatory information report

The fire resistance performance of various metal pipe penetrations in walls and floors protected with Hilti Firestop Sealant CP 606/CFS-S ACR



Client: Hilti Australia Pty Ltd

Product: Hilti Firestop Sealant CP 606/CFS-S ACR

Job number: FAS190231 Report number: 28418 Revision: RIR5.1

Issue date: 08/03/2021 Expiry date: 31/7/2023

DOCUMENT REVISION STATUS

Version	Date	Information relating to report			
RIR0.0	Issue: 24/07/2013	Reason for issue	Initial Issue		
			Prepared by	Reviewed by	Approved by
		Name	S. Hu	K.Nicholls	K.Nicholls
RIR1.0	Issue: 19/08/2015	Reason for issue	Revised pipe insulation thickness		
			Prepared by	Reviewed by	Approved by
		Name	S. Hu	K.Nicholls	K.Nicholls
RIR2.0	Issue: 8/04/2016	Reason for issue	Revised to include small metal pipes		
			Prepared by	Reviewed by	Approved by
		Name	D. Nichollson	K.Nicholls	K.Nicholls
RIR3.0	Issue: 30/07/2018	Reason for issue	Revised to extend validity for further 5 years.		
			Prepared by	Reviewed by	Approved by
		Name	M.Akl	O.Saad	O.Saad
RIR4.0	Issue: 06/01/2020	Reason for issue	Revise to include denser wall systems		
			Prepared by	Reviewed by	Approved by
		Name	Rami Al Darwish	Omar Saad	Omar Saad
RIR5.1	Issue: 08/03/2021	Reason for issue	Report issued to Hilti Australia Pty Ltd for review and comment.		
	Expiry: 31/07/2023	Name	Dugald Watson	Yomal Dias	Omar Saad
		Signature			

*RIR5.0 was skipped to maintain consistency with the referenced assessment report.

Contact information

Warringtonfire Australia Pty Ltd – ABN 81 050 241 524

Melbourne – NATA registered laboratory
Unit 2, 409-411 Hammond Road
Dandenong South, VIC 3175
Australia
T: +61 3 9767 1000

Sydney
Suite 802, Level 8
383 Kent Street
Sydney, NSW 2000
Australia
T: +61 2 9211 4333

Brisbane
Suite 6, Level 12
133 Mary Street
Brisbane, QLD 4000
Australia
T: +61 7 3238 1700

General conditions of use

This report may only be reproduced in full without modifications by the report sponsor. Copies, extracts or abridgments of this report in any form must not be published by other organisations or individuals without the permission of Warringtonfire Australia.

Warringtonfire Australia is not able to discuss the contents of this report with third parties without the consent of the report sponsor(s).

All work and services carried out by Warringtonfire Australia are subject to and conducted in accordance with our standard terms and conditions. These are available at <https://www.element.com/terms/terms-and-conditions> or on request.

CONTENTS

1	INTRODUCTION	5
2	TESTED PROTOTYPES	5
3	VARIATION TO TESTED PROTOTYPES	5
3.1	Distance Requirements	6
3.2	Penetrations in Walls and floors	7
3.3	Build up and pipe insulation details	9
3.4	Annular gap in walls and floors	12
4	REFERENCED TEST PROCEDURES	13
5	FORMAL ASSESSMENT SUMMARY	13
6	DIRECT FIELD OF APPLICATION	32
7	REQUIREMENTS	32
8	VALIDITY	32
9	AUTHORITY	33
	Applicant Undertakings and Conditions of Use	33
	General Conditions of Use	33

1 INTRODUCTION

This report contains the minimum information required for regulatory compliance and refers to the referenced assessment report 28418 R5.1.

This report presents the assessment outcome of the fire resistance performance of various metal pipe penetrations in wall and floor constructions protected with Hilti CP 606 if tested in accordance with AS 1530.4:2005 and assessed in accordance with AS 4072.1:2005.

The tested prototypes described in Section 2 of this report, when subject to the proposed variations described in Section 3, are to perform satisfactorily if tested in accordance with the referenced test method described in Section 4. The conclusions of the report are summarised in Section 5.

The validity of this assessment is conditional on compliance with Sections 7, 8 and 9 of this report.

Summaries of the test data on which this assessment is based are provided in the referenced assessment report 28418 R5.1 together with a summary of the critical issues leading to the assessment conclusions including the main points of argument.

2 TESTED PROTOTYPES

This assessment is based on reference test reports FSV 0855 and FSV 0857. The tests were sponsored by Hilti Australia Pty and were undertaken by CSIRO.

Reference is also made to test reports FRT 180461, FRT 190095, FRT 180049 and EWFA 2683500, FRT 180461a.1 and FRT 190130 which was sponsored by Hilti and conducted by Warringtonfire Aus Pty Ltd.

Supplementary reference is made to test report EWFA 2848300.2 which was sponsored by Speedpanel who has given permission for the use of test data in this assessment.

Supplementary reference is made to test report FRT 190130 which tests the fire resistance performance of various pipe and cable services through a 155 mm thick Dintel wall with polymer skins, filled with normal-weight concrete, protected by various Hilti fire protection systems including Fire resistance block CFS-BL, fire resistant plug CFS-PL, intumescent sealant CP 611A, acrylic sealant CP 606 and Hilti Firestop Putty Bandage CFS-P BA, in accordance with AS 1530.4:2014.

3 VARIATION TO TESTED PROTOTYPES

The proposed construction is to be as tested in FSV 0855 and FSV 0857, subject to the following variations:

- The metal pipes shall be copper, brass and ferrous (steel and iron) pipes with pipe sizes listed below. This information has been sourced from Table 10.11.3.1 of AS 1530.4:2005.

Table 1 Proposed pipe sizes

Pipe material	Nominal size (mm)	Pipe wall thickness (mm)
Copper, Ferrous or Brass pipes	Up to 65	0.91
	80-100	1.22
Copper or Ferrous (steel and iron) pipes	125	1.42
	150	1.63

- Copper, brass and ferrous pipes up to 150 mm diameter sealed to wall shall optionally be wrapped with mineral stone/rock wool insulation with thickness ≥ 38 mm and density ≥ 140 kg/mm³, or pre-formed mineral stone/rock wool insulation section with thickness ≥ 35 mm and density ≥ 115 kg/mm³ each side as per test EWFA 2683500, FRT 190095, FRT 180461.

- The plasterboard lined wall shall comprise either timber or steel studs lined on both faces with 2 layers of 13 mm thick or 1 or 2 layers of 16 mm thick fire grade plasterboard with or without cavity insulation and be tested or assessed to achieve the required FRL (depending on construction).
- The proposed clear spacing between penetrations shall be not less than 40 mm.
- Hilti Firestop Joint Sealant CP 606 is stated by the manufacturer to be identical to Hilti Firestop Joint Sealant CFS-S ACR and the only difference is the trade name. For the purpose of this assessment the product will be referred to as CP 606.
- Inclusion of walls comprised of concrete, solid or hollow masonry, aerated concrete with a minimum density of 510 kg/m³ (such as Hebel panel) or Speedpanel/Speedwall panels built to manufacturers specifications that have been tested or assessed to achieve the required FRL.
- PEF backing rod can be open or closed.
- Sealant can be filled to the full depth of the plasterboard so that the use of backing rod can be avoided.
- Fire rated plasterboard build up is allowed if floor slab thickness is less than 150 mm.
- The assigned FRL is also applicable to copper, brass and ferrous (steel and iron) and other metal pipes with lower heat conductivity than the unalloyed steel and a melting point of minimum 1100 °C, e.g. low alloyed steel, cast iron, stainless steel, Ni alloys, galvanised steel.
- For mineral stone/rock wool insulation, insulation material must overlap each other by at least 1 times the metal pipe diameter, such overlap is not required for pre-formed mineral stone/rock wool insulation section.
- Larger annular gap, up to 40 mm annular gap is allowed if mineral stone/rock wool is used as backing with 20 mm seal depth of CP 606. In this case, fire rated plasterboard build up must be applied and covering the annular gap both sides for wall and underneath the slab for floor. Two layers of plasterboards is needed to achieve an FRL of -/120/-, and one layer is needed to achieve an FRL of -/60/-. Mineral stone/rock wool insulation applied to obtain the assigned insulation rating.
- The FRL of the penetration system is limited to the FRL of the separating element.
- Minimum 155 mm thick Dincel walls, filled with normal-weight concrete, may also be used as the wall separating element.
- Separating element t_A refers to thickness including plasterboard build up.

3.1 DISTANCE REQUIREMENTS

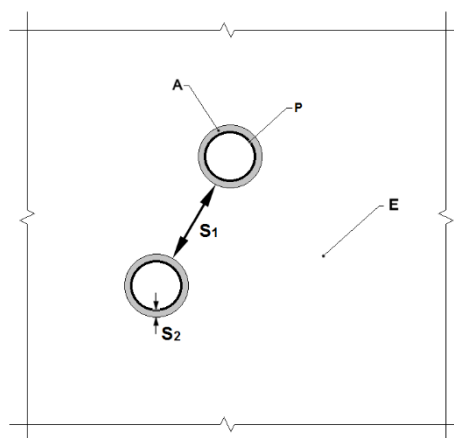

Figure 1 Distance requirements of penetrations (sealant to minimum depth of 20 mm)

Table 2 Distance requirements

Minimum distance valid for installations of services	Wall and floor (mm)
Distance between edges of individual penetrations for pipes	$S_1 = 40$
Distance between wall of pipe and edge of penetration	$5 \leq S_2 \leq 20$ for walls $5 \leq S_2 \leq 25$ for floors

The clear distance of 40 mm spacing between each pipe penetration should take account of the insulation wrapping if exists, the distance requirements apply to all pipe sizes approved.

3.2 PENETRATIONS IN WALLS AND FLOORS

- **4 Hour Rigid Wall (E)**

The wall must be tested or assessed to achieve an FRL of at least -/240/240 or 240/240/240 and comprise of concrete, solid or hollow masonry, aerated concrete with a minimum density of 550 kg/m³ or Speedpanel/Speedwall panels built to manufacturer's specifications.

For walls with thickness greater or equal to 230 mm, no build-up is required around the aperture. For walls with thickness less than 230 mm, build-up is required around the aperture to 230 mm thickness.

- **2 Hour Rigid Wall (E)**

The wall must be tested or assessed to achieve an FRL required, comprise of concrete, solid or hollow masonry, aerated concrete with a minimum density of 510 kg/m³ (Hebel panel), or Speedpanel/Speedwall panels built to manufacturers specifications. The wall separating element must have a minimum thickness of 75 mm. minimum 155 mm thick Dincel walls, filled with normal-weight concrete, may also be used as the wall separating element.

The FRL of the penetration system is limited to the FRL of the separating element.

- **2 Hour Flexible Wall (E)**

The wall must be tested or assessed to achieve an FRL of -/120/120 or 120/120/120 and comprise of either timber or steel studs lined on both faces with 2 layers of 13 mm thick or 1 or 2 layers of 16 mm thick fire grade plasterboard with or without cavity insulation with a minimum wall track width of 64 mm.

For walls with thickness greater or equal to 150 mm, no build-up is required around the aperture. For walls with thickness less than 150 mm, build-up is required around the aperture unless insulation wrap is installed. If insulation wrap is installed build-up is only required for wall thickness less than 100 mm.

- **1.5 Hour Flexible wall (E)**

The wall must be tested or assessed to achieve an FRL of -/90/90 or 90/90/90 and comprise of either timber or steel studs lined on both faces with 2 layers of 13 mm thick or 1 or 2 layers of 16 mm thick fire grade plasterboard with or without cavity insulation with a minimum wall track width of 64 mm.

For walls with thickness greater or equal to 150 mm, no build-up is required around the aperture. For walls with thickness less than 150 mm, build-up is required around the aperture unless insulation wrap is installed. If insulation wrap is installed build-up is only required for wall thickness less than 100 mm.

- **1 Hour Flexible wall (E)**

The wall must be tested or assessed to achieve an FRL of -/60/60 or 60/60/60 and comprise of either timber or steel studs lined on both faces with 1 layer of 13 mm thick or 1 or 2 layers of 16 mm thick fire grade plasterboard with or without cavity insulation with a minimum wall track width of 64 mm.

For walls with thickness greater or equal to 90 mm, no build-up is required around the aperture. For walls with thickness less than 90 mm, build-up is required around the aperture. Walls lined with 1 layer of 13 mm plasterboard require additional build-up of 1 layer of 13 mm plasterboard around the penetration.

- **4 Hour Rigid floor (E)**

The floor must have a minimum bare concrete separating element thickness of 120 mm. Aperture framing/beading shall be applied to achieve necessary thickness of 150 mm locally. Build up is not required for floors with thicknesses equal to or greater than 150 mm.

The metal pipe shall be positioned at the centre of the core hole leaving an annular gap no less than 5 mm. The maximum annular gap allowed is 25 mm. The gap shall be filled with Hilti CP 606 to a minimum depth of 30 mm and backed with PE backing rod (BR) or mineral stone/rock wool.

The FRL assigned applies to the installation configuration where PVC pipe section or Hilti cast in collar CP680/CP680P/CP680PX/CP680M casted in floor can remain in the concrete floor.

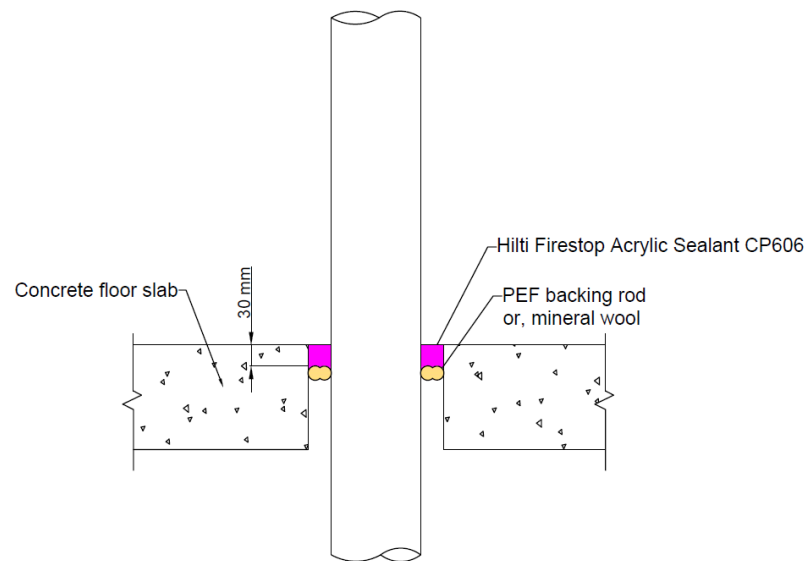

Figure 2 Generic floor penetration configuration

- **Aperture sealant protection (A)**

The annular gap around pipes shall be a minimum of 5 mm wide and a maximum of 25 mm wide. The gap shall be filled with Hilti CP 606 (A) to a minimum depth of 20 mm and backed with PE backing rod (BR). For single layer plasterboard walls where minimum depth of 20 mm cannot be achieved, aperture framing/beading shall be used in order to achieve necessary depth of plasterboard. Specification and fixing of build-up details for single layer board should always be as per the fire rated plasterboard wall installation detail.

- **Aperture Framing/Beading Details for Walls (E1 and E2)**

For Speedpanel walls:

Aperture Framing/Beading shall be constructed from either fire rated plasterboard or calcium silicate board (E1), or Hebel panel (E2). Hebel panel beading shall be on one side of concrete, solid or hollow masonry and aerated concrete walls only. The aperture framing/beading shall be of a size which will surround the intended aperture by at least 50 mm (WA) and of sufficient thickness to make the total aperture thickness (t_A) \geq 230 mm for 4-hour performance or (t_A) \geq 150 mm for 2 hour or 1.5-hour performance or (t_A) \geq 75 mm for 1 hour performance.

Where beading is applied to Speedpanel/Speedwall, all gaps in the profiled face of the panel shall be filled with CP 606 sealant. Aperture Framing/Beading shall be constructed from fire rated plasterboard or calcium silicate board (E1) as per Figure 3.

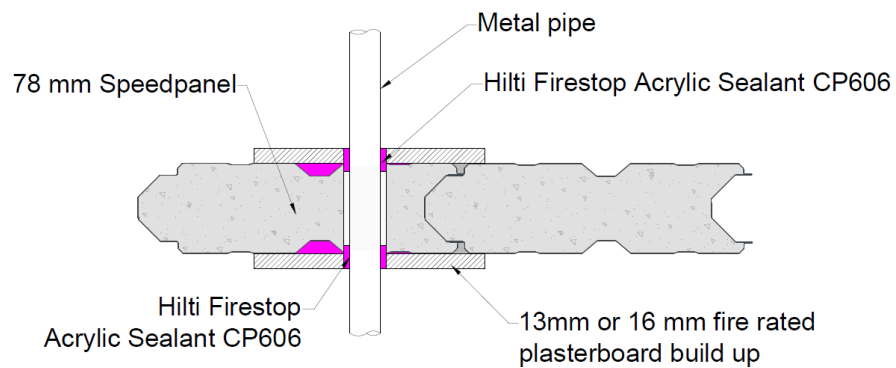

Figure 3 Horizontal cross section for build-up and sealant in Speedpanel/Speedwall

3.3 BUILD UP AND PIPE INSULATION DETAILS

Plasterboard built up for wall and floor:

Aperture Framing/Beading shall be constructed from fire rated plasterboard or calcium silicate boards (E1) of a size which will surround the intended aperture by at least 50 mm (WA) installed with the necessary number of layers to achieve total aperture thickness (t_A) \geq 128 mm for 2 hour or 1.5 hour performance or (t_A) \geq 90 mm for 1 hour performance. Specification and fixing of build-up details for single layer board should always be as per the fire rated plasterboard wall installation detail.

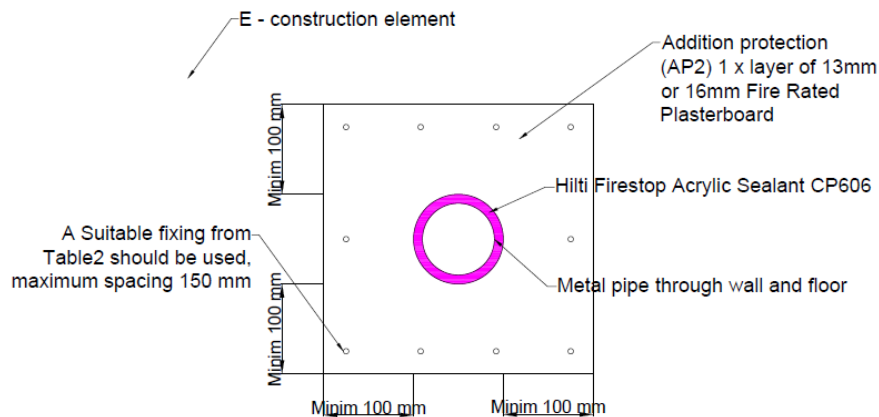

Figure 4 Elevation of aperture framing / beading and position of the seal in walls

Table 3 Anchor/Fixing Types

Anchoring System		Minimum Size	Flexible Wall (Plasterboard lined)	Aerated Concrete Wall (Hebel)	Solid Concrete Walls & Floors	
Hilti Screw Anchor	HUS3-P	M6		✓*	✓	
	HUS3-H			✓*	✓	
	HUS			✓*	✓	
Hilti Expansion Anchor	HSA					✓
	HST					✓
	DBZ 6/45					✓
	HFB					✓
Hilti Cavity Anchor	HTB-S		✓			
	HHD-S		✓			
Others	#14/10x65mm Hex Head Type 17 Screw	14g		✓		
	Laminating / Drywall / Plasterboard Screws, with steel washers of at least 19mm in diameter, length as required.	10g	✓			
	Threaded Rod with Nuts & Washer	M6	✓	✓	✓	

* Note: Minimum length of Hilti HUS screw required for Aerated Concrete (Hebel) = 60mm

Pipe Insulation Protection (A₂)

Pipe may be insulated with mineral stone/rock wool insulation with thickness ≥ 38 mm and density ≥ 140 kg/mm³, or pre-formed mineral stone/rock wool insulation section with thickness ≥ 35 mm and density ≥ 115 kg/mm³. For wall penetration, the metal pipe shall be wrapped on both exposed and unexposed sides for the pipe insulation length (L_{pi}) specified in the table in Section 5 with steel cable ties 50 mm from each end and at 250 mm centres.

A bead of CP 606 sealant shall be applied at the junction of the mineral stone/rock wool wall insulation and wall as per **Figure 5**.

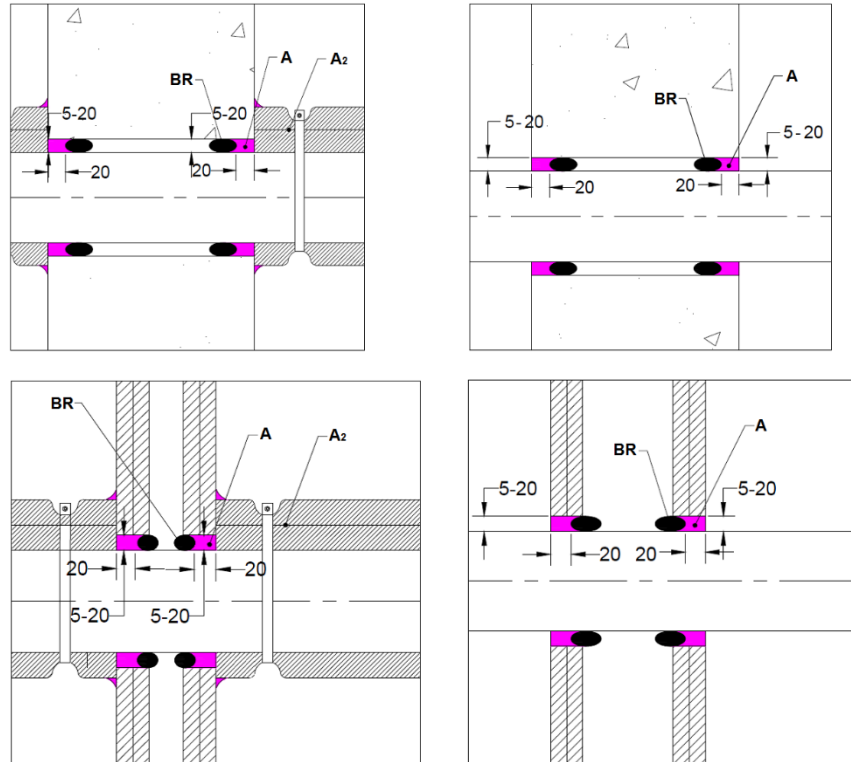

Figure 5 Sealant detail for Rigid and Flexible walls with and without pipe insulation

Table 4 Figure item descriptions

Item	Description	Item	Description
A	Hilti CP 606 to a depth of 20mm (as shown above)	A ₂	38mm or 50mm thick Bradford Fibertex 450 Rockwool
E	Building elements wall refer to section 3.2 for wall specification	W _A	Distance from edge of penetration to edge of beading frame
E ₁	Fire rated plasterboard or calcium silicate boards. Specification and fixing of build-up details for single layer board should always be as per the Fire Rated plasterboard wall installation detail. Refer to Aperture Framing/Beading Details for Walls section above	E ₂	Hebel panel build-up (Hebel panel on one side of concrete, solid or hollow masonry and aerated concrete walls only). Refer to Aperture Framing/Beading Details for Walls section above
t _A	Thickness of penetration seal	t _E	Thickness of the building element
P	Pipe	BR	PE Backing Rod
F	Fixing for Hebel Panel build-up (14-10 x 100mm type 17 hex head screw)		

3.4 ANNULAR GAP IN WALLS AND FLOORS

Annular gap greater than 20 mm is allowed if the following configurations are installed on site. For metal pipe through wall separating element, a maximum 40 mm annular gap is allowed with single layer fire rated 16 mm plasterboard build up each side of the wall and a 10 mm x 10 mm CP 606 fillet to be applied between pipes and build up plasterboard. Please refer to section 3.3 for build-up detail.

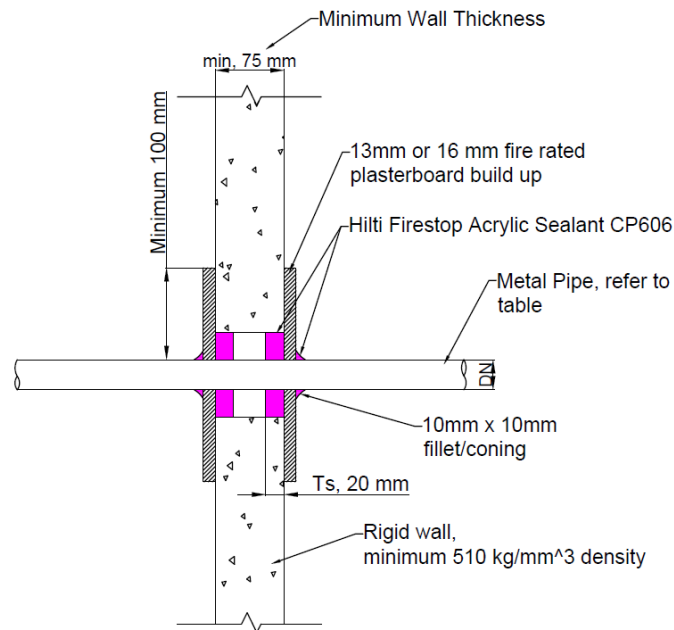

Figure 6 Larger annular gaps in wall configurations

Annular gap greater than 20 mm is allowed if the following configurations are installed on site. For metal pipe through floor separating element, a maximum 40 mm annular gap is allowed with single layer fire rated 16 mm plasterboard build up underneath the floor and a 10 mm x 10 mm CP 606 fillet to be applied between pipe and build up plasterboard. Please refer to section 3.3 for build-up detail.

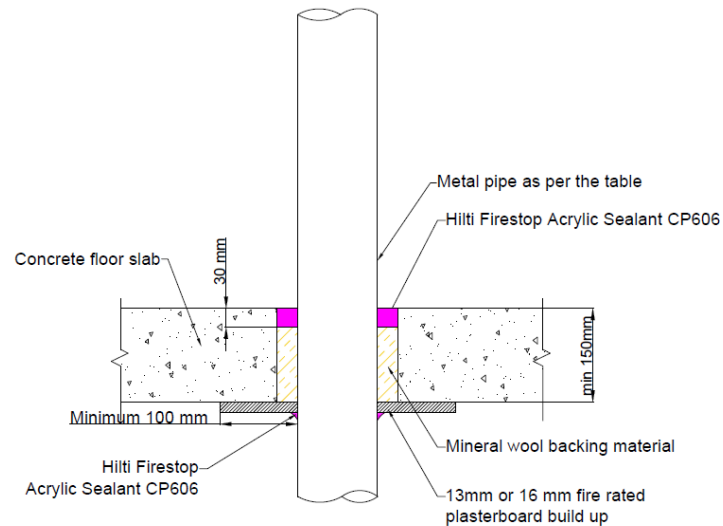

Figure 7 Larger annular gaps in floor configurations

4 REFERENCED TEST PROCEDURES

This report is prepared with reference to the requirements of AS 1530.4:2005 Section 10 and AS 4072.1:2005.

5 FORMAL ASSESSMENT SUMMARY

Based on the discussion presented in referenced assessment report 28418 R5.1, it is the opinion of this testing authority that if the specimen described in section 2 had been modified within the scope of section 3, it will achieve the performance as stated below if tested in accordance with the test method referenced in Section 4 and subject to the requirements of Section 7.

**1 hr FRL Single layer plasterboard
 FRL -/60/60
 Metal pipe protected with Hilti CP 606**

The wall shall have a minimum thickness of 90 mm (t_A) and comprise of steel/timber stud lined on both faces with minimum one layer of 13 mm or 16 mm thick fire grade plasterboard (E) and has been tested or otherwise assessed to achieve FRL 60/60/60 or FRL -/60/60, with or without cavity insulation (E_2). The minimum steel track width is 64 mm.

The annular gap around pipes shall be a minimum of 5 mm and a maximum of 20 mm wide. The gap shall be filled with Hilti CP 606 to a minimum depth of 20 mm and backed with PE backing rod (BR) or mineral stone/rock wool.

For single layer plasterboard wall where minimum depth of 20 mm cannot be achieved, aperture framing/beading shall be used to achieve necessary depth of plasterboard. Specification and fixing of build-up detail, please refer to section 3. A core-hole size of around 20 mm greater than the outer diameter of the metal pipe is recommended creating an annular gap of around 10 mm to allow easy caulking to 20 mm deep is required.

PEF backing rod can be open or closed, sealant can be filled full depth or a minimum of 20 mm of the plasterboard so that the use of backing rod can be avoided.

The metal pipe shall be copper, brass and ferrous (steel and iron) pipes specified in the assessment table, stainless and galvanised pipes are also included.

Pipe insulation can either be mineral stone/rock wool with greater density and thickness, or Bradford Fibertex 450.

Mineral stone/rock wool insulation must be overlapped by a minimum length equivalent to the pipe diameter. Such overlap is not required for pre-formed mineral stone/rock wool section.

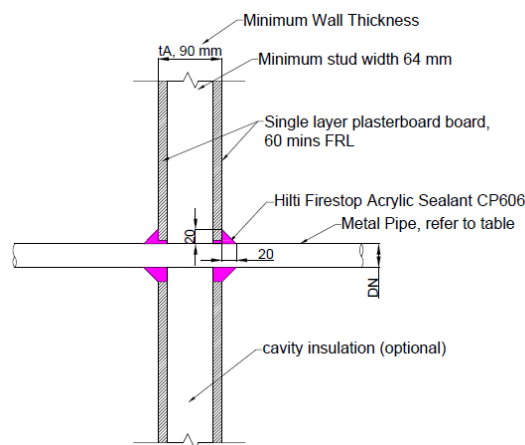

Figure 8 Side View - 1hr FRL single layer plasterboard with sealant only

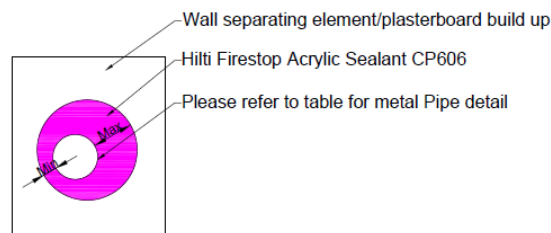

Figure 9 Front view – annular gap

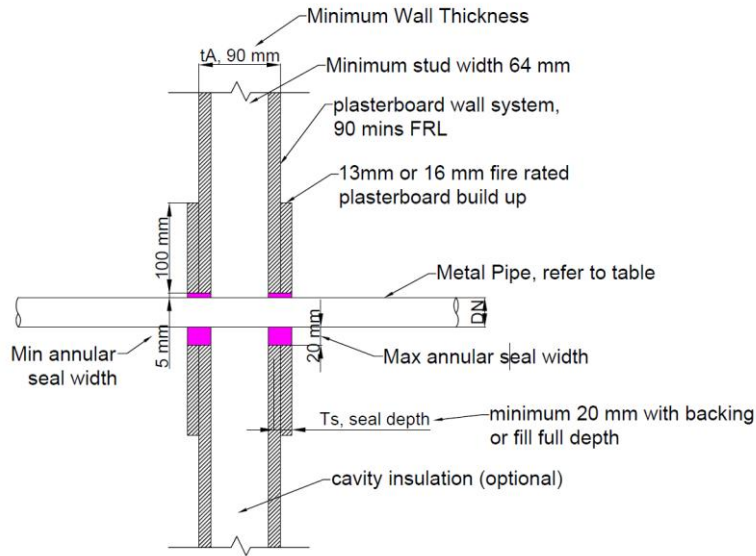

Figure 10 Side view – 1hr FRL single layer plasterboard with sealant and plasterboard build-up

Table 5 Assessment summary of metal pipe configuration as per Figure 8 and Figure 9

Metal pipe material	Separating element, t _A	Build up detail	Pipe nominal diameter, DN (mm)	Min pipe wall thickness (mm)	Annular gap (mm)	Sealant depth (mm)	Insulation	FRL
Copper, ferrous or brass	1 hr FRL single layer plasterboard	N/A	Up to 65	0.91	5-20	Full depth of single layer plasterboard with 20 mm × 20 mm fillet	None	-/60/-
			80-100	1.22				
Copper, ferrous (steel and iron)			125	1.42				
			150	1.63				

Table 6 Assessment summary of metal pipe configuration as per Figure 10

Metal pipe material	Separating element, t _A	Build up detail	Pipe nominal diameter, DN (mm)	Min pipe wall thickness (mm)	Annular gap (mm)	Sealant depth (mm)	Insulation	FRL
Copper, ferrous or brass	1 hr FRL single layer plasterboard	min. 13 mm fire rated plasterboard build up each side locally around the Copper pipe penetration	Up to 65	0.91	5-20	Full depth of two layers of plasterboard	None	-/60/-
			80-100	1.22				
Copper, ferrous (steel and iron)			125	1.42				
			150	1.63				

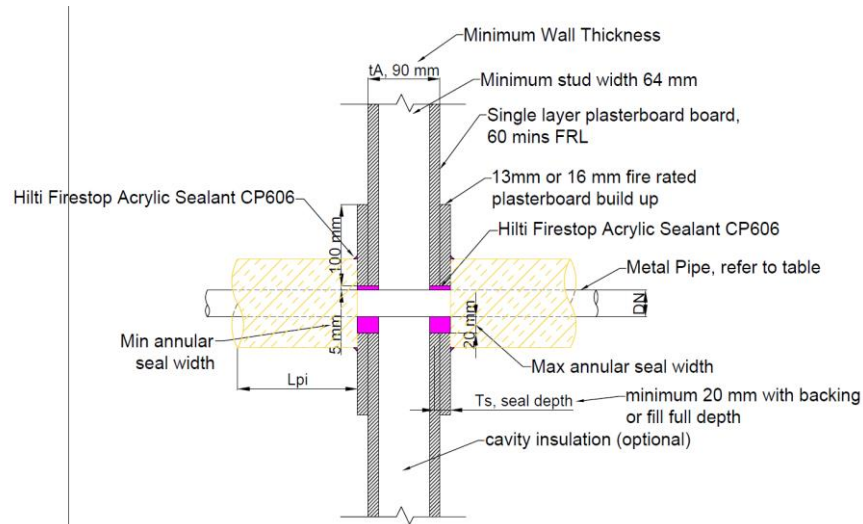

Figure 11 Side view – 1hr FRL single layer plasterboard with sealant, plasterboard build-up and mineral wool insulation

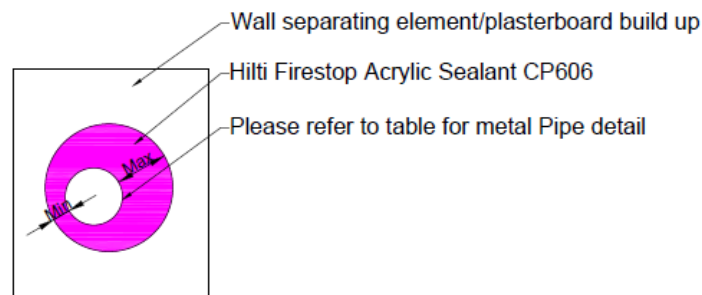

Figure 12 Front view – Annular Gap

Table 7 Assessment summary of metal pipe configuration as per Figure 11 and Figure 12

Metal pipe material	Separating element, t_A	Build up detail	Pipe nominal diameter, (mm)	Min pipe wall thickness (mm)	Annular gap (mm)	Sealant depth (mm)	Insulation	insulation length (mm)	FRL
Copper, ferrous or brass	1 hr FRL single layer plasterboard	13mm plaster board build up each side locally around the Copper pipe penetration	Up to 15	0.91	5-20	Full depth of plasterboard	Mineral stone/rock wool insulation, or pre-formed mineral stone/rock wool insulation installed on each side of the wall	200	-/60/60
			20-32	0.91				300	
			40-65	0.91				400	
			80-100	1.22				500	
			125	1.42				600	
Copper, ferrous (steel and iron)			150	1.63					

90 mins FRL plasterboard system

FRL -/90/90

Metal pipe protected with Hilti CP 606

The wall shall have a minimum thickness of 96 mm (t_A) and comprise of steel/timber stud lined on both faces with minimum two layers of 13 mm or one or two layers of 16 mm thick fire grade plasterboard (E) and has been tested or otherwise assessed to achieve FRL 90/90/90 or FRL -/90/90, with or without cavity insulation (E_2).

The annular gap around pipes shall be a minimum of 5 mm and a maximum of 20 mm wide. The gap shall be filled with Hilti CP 606 to a minimum depth of 20 mm and backed with PE backing rod (BR) or mineral stone/rock wool.

For plasterboard wall where minimum depth of 20 mm cannot be achieved, aperture framing/beading shall be used to achieve necessary depth of plasterboard. Specification and fixing of build-up detail, please refer to section 3. A core-hole size of around 20 mm greater than the outer diameter of the metal pipe is recommended creating an annular gap of around 10 mm to allow easy caulking to 20 mm deep is required.

PEF backing rod can be open or closed, sealant can be filled full depth (minimum 20 mm) of the plasterboard so that the use of backing rod can be avoided.

Pipe insulation can either be mineral stone/rock wool with greater density and thickness, or Bradford Fibertex 450.

Mineral stone/rock wool insulation must be overlapped by a minimum length equivalent to the pipe diameter. Such overlap is not required for pre-formed mineral stone/rock wool section.

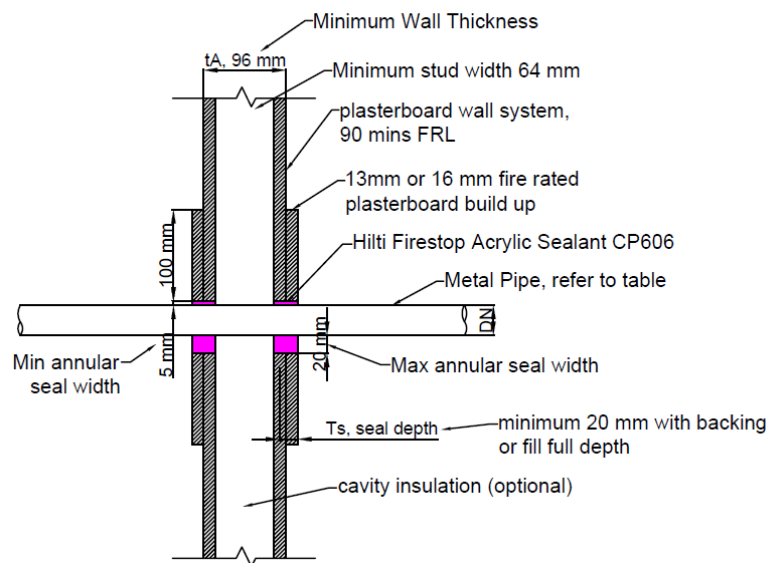

Figure 13 Side view – 90 mins FRL plasterboard system with sealant and plasterboard build-up

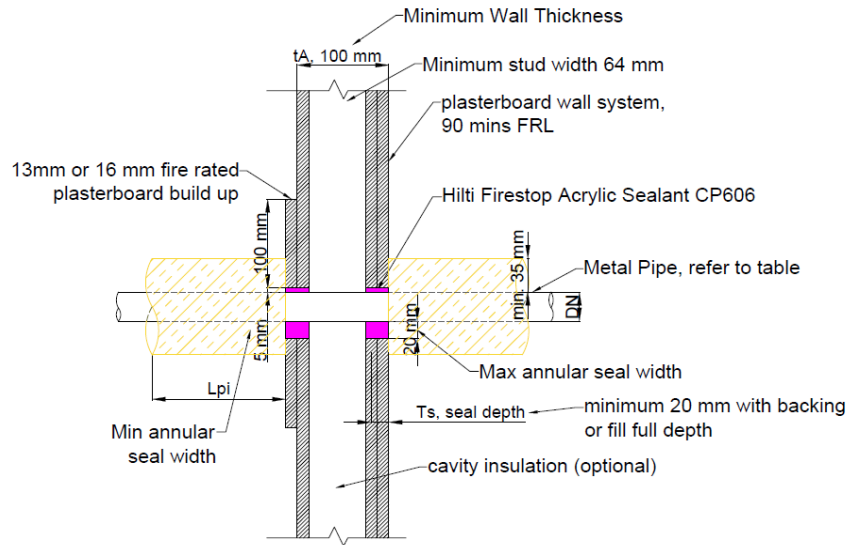

Figure 14 Side view – 90 mins FRL plasterboard system with sealant, plasterboard build-up and mineral wool insulation

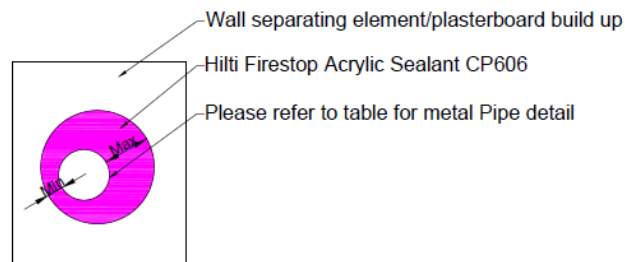

Figure 15 Front view – Annular gap

Table 8 Assessment summary of metal pipe configuration as per Figure 13

Metal pipe material	Separating element, t_A	Build up detail	Pipe nominal diameter, (mm)	Min pipe wall thickness (mm)	Annular gap (mm)	Sealant depth (mm)	Insulation	FRL
Copper, ferrous or brass	90 mins plasterboard wall	13 mm plasterboard build up each side locally around the Copper pipe penetration	Up to 65	0.91	5-20	20	None	-90/-
			80-100	1.22				
			125	1.42				
			150	1.63				
Copper, ferrous (steel and iron)								

Table 9 Assessment summary of metal pipe configuration as per Figure 14

Metal pipe material	Separating element, t _A	Build up detail	Pipe nominal diameter, DN (mm)	Mini pipe wall thickness (mm)	Annular gap (mm)	Sealant depth (mm)	Pipe insulation config	insulation length (mm)	FRL
Copper, ferrous or brass	90 mins plasterboard wall	13 mm plasterboard build up each side locally around the Copper pipe penetration	15	0.91	5-20	Full depth of two layers of plasterboard	Mineral rock wool insulation, or preformed mineral rock wool insulation, installed on each side of the wall	200	- /90/90
			20-32	0.91				300	
			40-65	0.91				400	
			80-100	1.22				500	
			125	1.42				600	
Copper, ferrous (steel and iron)			150	1.63					

2 hr FRL Plasterboard walls

FRL -/120/120

Metal pipe protected with Hilti CP 606

The wall shall have a minimum thickness of 100 mm (t_A) and comprise of steel/timber stud lined on both faces with minimum two layers of 13 mm or 16 mm thick fire grade plasterboard (E) and has been tested or otherwise assessed to achieve FRL 120/120/120 or FRL -/120/120, with or without cavity insulation (E_2).

The annular gap around pipes shall be a minimum of 5 mm and a maximum of 20 mm wide. The gap shall be filled with Hilti CP 606 to a minimum depth of 20 mm and backed with PE backing rod (BR) or mineral stone/rock wool.

A core-hole size of 20 mm greater than the outer diameter of the metal pipe is recommended creating an annular gap of 10 mm.

PEF backing rod can be open or closed, sealant can be filled full depth of the plasterboard so that the use of backing rod can be avoided.

The metal pipe shall be copper, brass and ferrous (steel and iron) pipes specified in the assessment table, stainless and galvanised pipe is also included.

Pipe insulation can either be mineral stone/rock wool with greater density and thickness, or Bradford Fibertex 450.

Mineral stone/rock wool insulation must be overlapped by a minimum length equivalent to the pipe diameter. Such overlap is not required for pre-formed mineral stone/rock wool section.

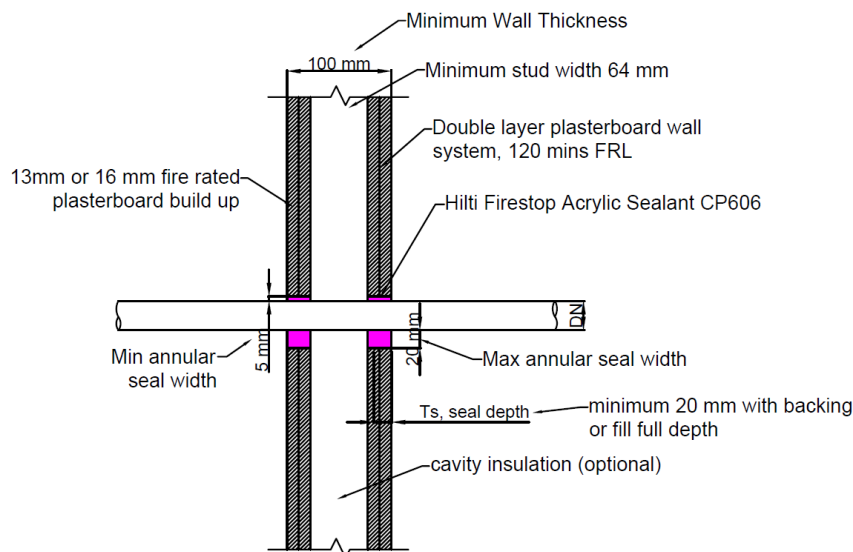

Figure 16 Side view – 120 mins FRL plasterboard system with sealant only

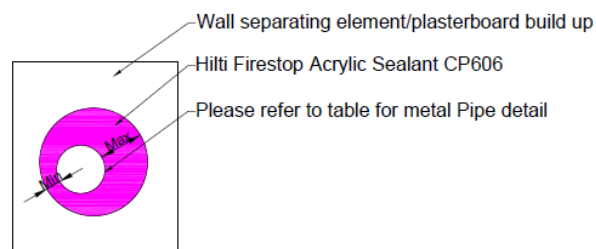

Figure 17 Front view – Annular gap

Table 10 Assessment summary of metal pipe configuration as per Figure 16

Metal pipe material	Separating element, t _A	Build up detail	Pipe nominal diameter, DN (mm)	Minimum pipe wall thickness (mm)	Annular gap (mm)	Sealant depth (mm)	Pipe insulation configuration	FRL
Copper, ferrous or brass	2 hr FRL double layer plasterboard wall system	N/A	Up to 65	0.91	5-20	20	None	-/120/-
			80-100	1.22				
Copper, ferrous (steel and iron)			125	1.42				
			150	1.63				

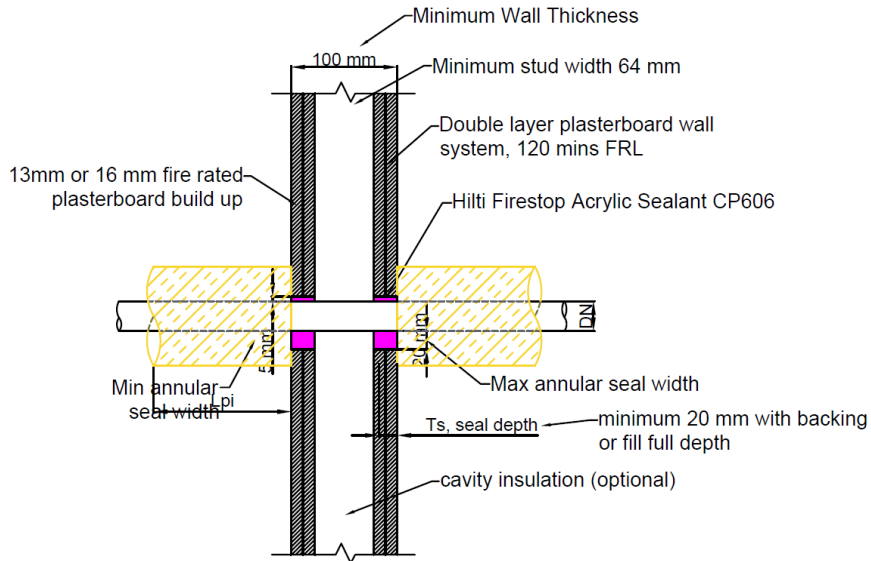

Figure 18 Side view – 120 mins FRL plasterboard system with sealant and mineral wool insulation

Table 11 Assessment summary of metal pipe configuration as per Figure 18

Metal pipe material	Separating element, t _a	Build up detail	Pipe nominal diameter, DN (mm)	Minimum pipe wall thickness (mm)	Annular gap (mm)	Sealant depth (mm)	Pipe insulation config	Insulation length (mm)	FRL
Copper, ferrous or brass	120 FRL double layer plasterboard	Not required	15	0.91	5-20	Full depth of two layers of plasterboard	mineral rock wool insulation, or preformed mineral rock wool insulation, installed on each side of the wall	200	- /120/120
			20-32	0.91				300	
			40-65	0.91				400	
			80-100	1.22				500	
125			1.42	600					
Copper, ferrous (steel and iron)			150	1.63					

2 hr FRL Rigid Walls

FRL -/120/120

Metal pipe protected with Hilti CP 606

The bare wall must have a minimum thickness of 75 mm and comprise of concrete, aerated concrete, Hebel, or hollow masonry with a minimum density of 510 kg/m³.

When the bare wall thickness is greater than 150 mm, CP 606 sealant fillet is not needed.

The annular gap around pipes shall be a minimum of 5 mm and a maximum of 20 mm wide. The gap shall be filled with Hilti CP 606 to a minimum depth of 20 mm and backed with PE backing rod (BR) or mineral stone/rock wool.

A minimum 20 mm by 20 mm fillet/coning is required on both sides for -/120/- FRL rating. If the wall thickness is greater than 150 mm, coning is then not required, the seal can be done flush with the wall surface.

Minimum 155 mm thick Dintel walls, filled with normal-weight concrete, may also be used as the wall separating element.

A core-hole size of around 20 mm greater than the outer diameter of the metal pipe is recommended creating an annular gap of around 10 mm to allow easy caulking to 20 mm deep required.

PEF backing rod can be open or closed, sealant can be filled full depth of the wall so that the use of backing rod can be avoided.

The metal pipe shall be copper, brass and ferrous (steel and iron) pipes specified in the assessment table, stainless and galvanised pipe is also included.

Pipe insulation can either be mineral stone/rock wool with greater density and thickness, or Bradford Fibertex 450.

Mineral stone/rock wool insulation must be overlapped by a minimum length equivalent to the pipe diameter. Such overlap is not required for pre-formed mineral stone/rock wool section.

The FRL of the wall governs the FRL of the firestop solution.

The FRL assigned applies to the installation configuration where PVC pipe section casted in the wall remains in the wall.

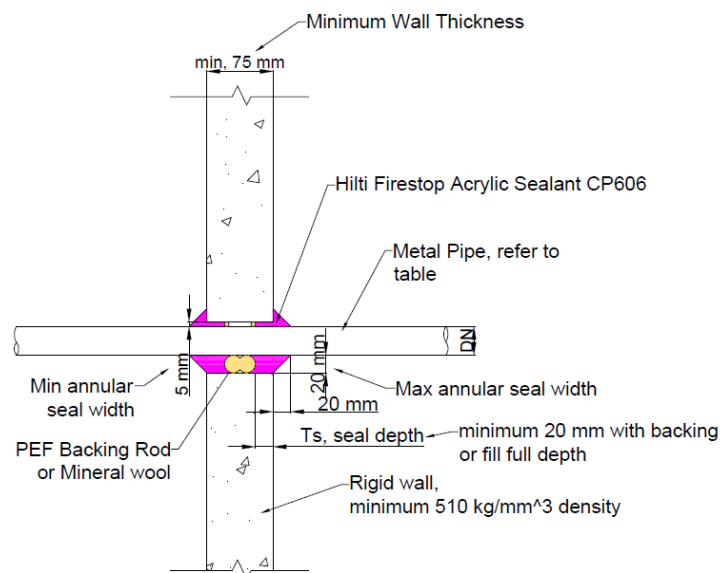

Figure 19 Side view – 120 mins FRL rigid wall system with sealant only

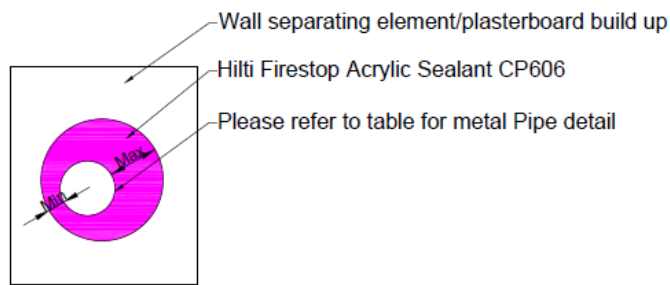

Figure 20 Front view – annular gap

Table 12 Assessment summary of metal pipe configuration as per Figure 19

Metal pipe material	Separating element, t_A	Build up detail	Pipe nominal diameter, DN (mm)	Min pipe wall thickness (mm)	Annular gap (mm)	Sealant depth (mm)	Backing configuration	Fillet/concoring	FRL
Copper, ferrous or brass	Rigid wall, min 75 mm, with a min density of 510 kg/m ³	Only required for Speedpanel, single layer of fire rated plasterboard 13 mm or 16 mm each side.	Up to 65	0.91	5-20	20	PEF backing rod, CF 116, CF-F 750 GV, CF 126 or mineral rock wool	20 mm x 20 mm fillet (both sides)	-/120/-
			80-100	1.22					
125			1.42						
150			1.63						
Copper, ferrous (steel and iron)	Speedpanel								

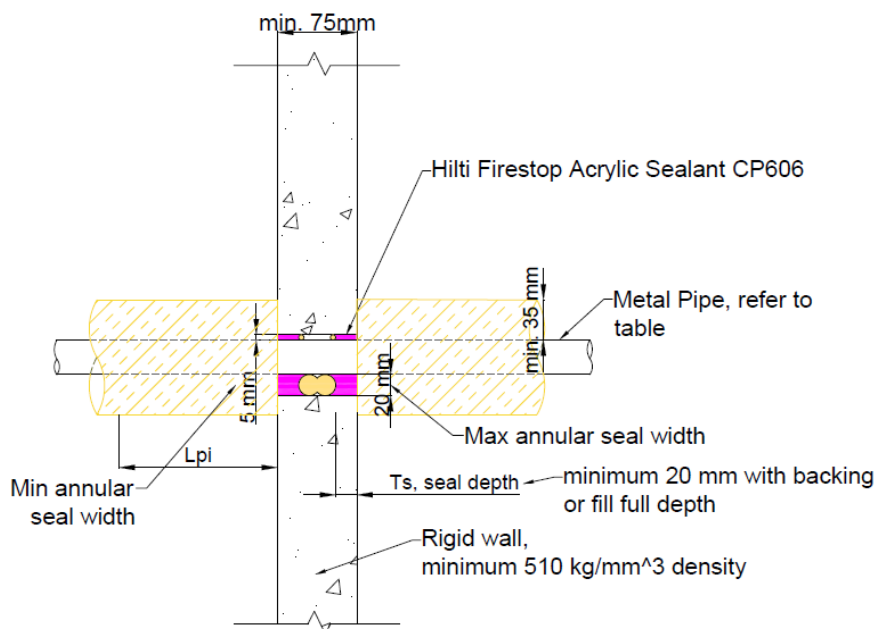

Figure 21 Side view – 120 mins FRL rigid wall system with sealant and mineral wool insulation

Table 13 Assessment summary of metal pipe configuration as per Figure 21

Metal pipe material	Separating element, t _A	Build up detail	Pipe nominal diameter, DN (mm)	Min pipe wall thickness (mm)	Annular gap (mm)	Sealant depth (mm)	Backing configuration	Pipe insulation configuration	Insulation Length (mm)	FRL
Copper, ferrous or brass	Rigid wall, min 75mm, with a min density of 510 kg/m ³	Only required for Speedpanel, single layer of fire rated plasterboard 13 mm or 16 mm each side.	15	0.91	5-20	20	PEF backing rod, CF 116, CF-F 750 GV, CF 126 or mineral rock wool	mineral rock wool insulation, or preformed mineral rock wool insulation, installed on each side of the wall	200	- /120/60
			20-32	0.91					300	
			40-65	0.91					400	
			80-100	1.22					500	
			125	1.42					600	
Copper, ferrous (steel and iron)	Speedpanel		150	1.63						

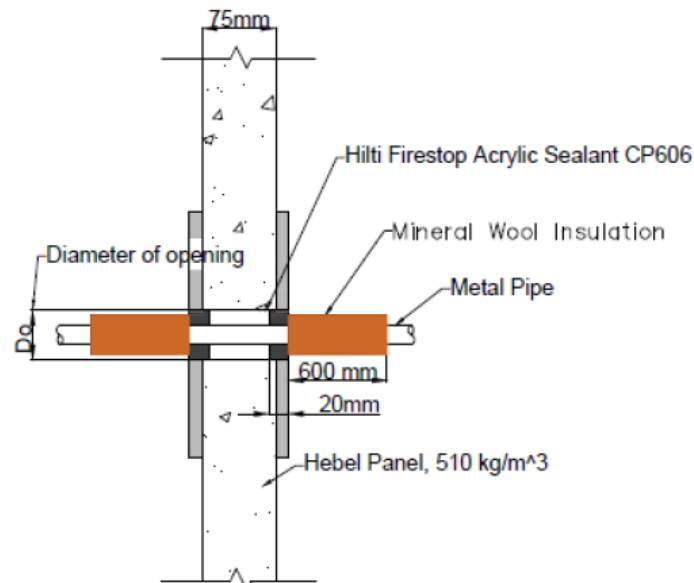

Figure 22 Side view – 120 mins FRL rigid wall system with sealant, plasterboard build-up and mineral wool insulation

Table 14 Assessment summary of metal pipe configuration as per Figure 22

Metal pipe material	Separating element, t _A	Build up detail	Pipe nominal diameter, DN (mm)	Min pipe wall thickness (mm)	Annular gap (mm)	Sealant depth (mm)	Backing config	Pipe insulation config	Insulation Length (mm)	FRL
Copper, ferrous or brass	Rigid wall, min 75mm, with a min density of 510 kg/m ³	Single layer of fire rated plasterboard 13 mm or 16 mm each side.	15	0.91	5-20	20	PEF backing rod, CF 116, CF-F 750 GV, CF 126 or mineral rock wool	mineral rock wool insulation, or preformed mineral rock wool insulation, installed on each side of the wall	200	- /120/120
			20-32	0.91					300	
			40-65	0.91					400	
			80-100	1.22					500	
			125	1.42					600	
Copper, ferrous (steel and iron)	Speedpanel		150	1.63						

4 hr FRL Rigid Walls FRL -/240/240 Metal pipe protected with Hilti CP 606

The wall must have a minimum thickness of 230 mm and comprise of concrete, aerated concrete, or hollow masonry with a minimum density of 510kg/m³.

The annular gap around pipes shall be a minimum of 5 mm and a maximum of 20 mm wide. The gap shall be filled with Hilti CP 606 to a minimum depth of 20 mm and backed with PE backing rod (BR) or mineral stone/rock wool.

Aperture framing/beading shall be used to achieve necessary wall thickness of 230 mm locally. Specification detail on build up and fixing, please reference to section 3. A core-hole size of around 20 mm greater than the outer diameter of the metal pipe is recommended creating an annular gap of around 10 mm to allow easy caulking to 20 mm deep required.

PEF backing rod can be open or closed, sealant can be filled full depth of the wall so that the use of backing rod can be avoided.

The metal pipe shall be copper, brass and ferrous (steel and iron) pipes specified in the assessment table, stainless and galvanised pipe is also included.

Pipe insulation can either be mineral stone/rock wool with greater density and thickness, or Bradford Fibertex 450.

Mineral stone/rock wool insulation must be overlapped by a minimum length equivalent to the pipe diameter. Such overlap is not required for pre-formed mineral stone/rock wool section.

The FRL of the wall governs the FRL of the firestop solution.

The FRL assigned applies to the installation configuration where PVC pipe section casted in the wall remains in the wall.

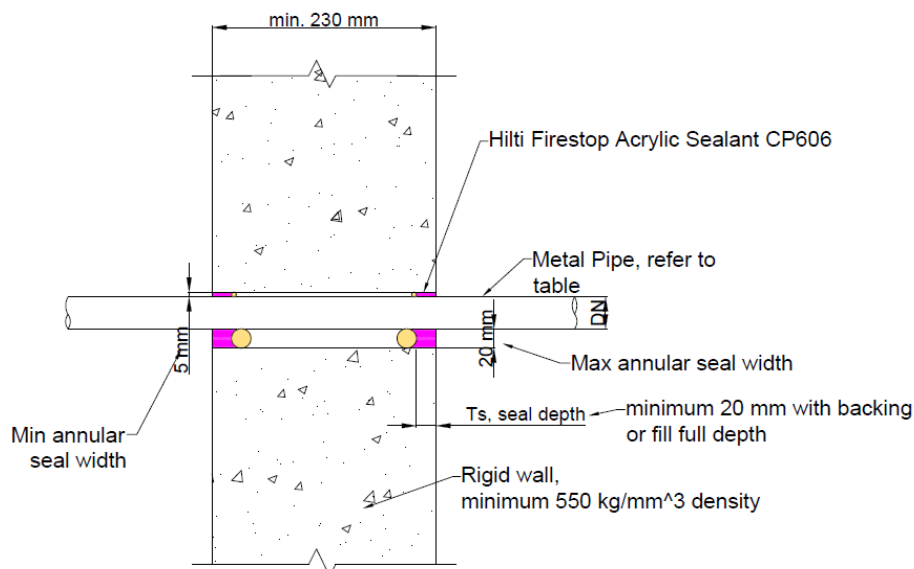

Figure 23 Side view – 240 mins FRL rigid wall system with sealant only

Table 15 Assessment summary of metal pipe configuration as per Figure 23

Metal pipe material	Separating element, t_A	Build up detail	Pipe nominal diameter, DN (mm)	Min pipe wall thickness (mm)	Annular gap	Sealant depth (mm)	Backing config	Insulation	FRL
Copper, ferrous or brass	Rigid wall, min 230 mm, with a min density of 550 kg/m ³	only required if the bare wall thickness is less than 230 mm	Up to 65	0.91	5-20	20	PEF backing rod, CF 116, CF-F 750 GV, CF 126 or mineral rock wool	None	-/240/-
80-100			1.22						
125			1.42						
150			1.63						
Copper, ferrous (steel and iron)									

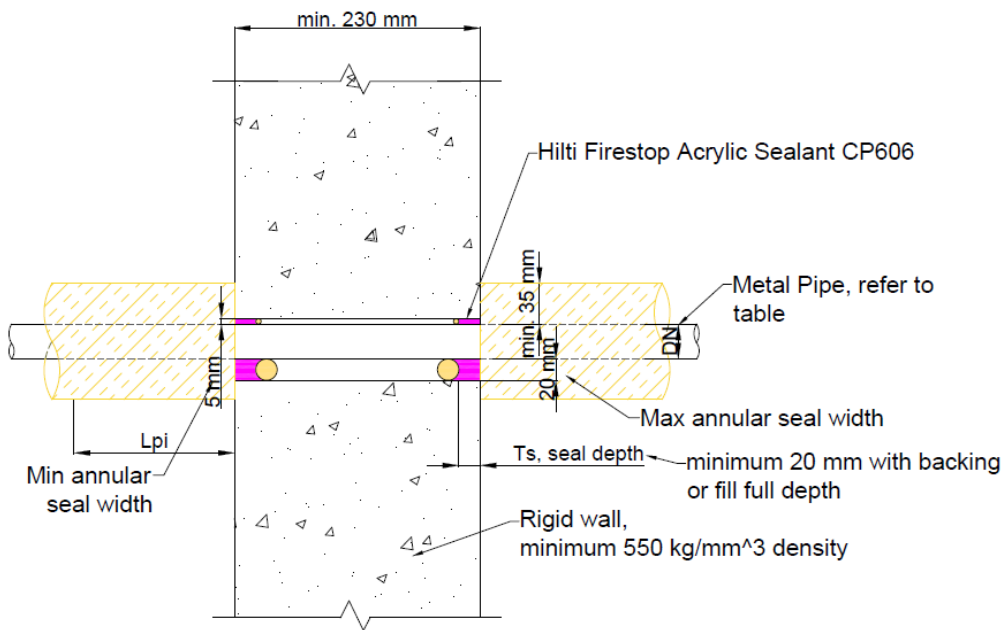

Figure 24 Side view – 240 mins FRL rigid wall system with sealant and mineral wool insulation

Table 16 Assessment summary of metal pipe configuration as per Figure 24

Metal pipe material	Separating element, t _A	Build up detail	Pipe nominal diameter, DN (mm)	Min pipe wall thickness (mm)	Annular gap (mm)	Sealant depth (mm)	Backing config	Pipe insulation config	Insulation length (mm)	FRL
Copper, ferrous or brass	Rigid wall, min 230 mm, with a min density of 510 kg/m ³	only required if the bare wall thickness is less than 230 mm	Up to 15	0.91	5-20	20	PEF backing rod, CF 116, CF-F 750 GV, CF 126 or mineral rock wool	mineral rock wool insulation, or preformed mineral rock wool insulation, installed on each side of the wall	200	-/240/120
			20-32	0.91					300	
			40-65	0.91					400	
			80-100	1.22					500	
			125	1.42					600	
150	1.63									
Copper, ferrous (steel and iron)										

4 hr FRL Rigid floor

Metal pipe protected with Hilti CP 606

The floor must have a minimum bare concrete separating element thickness of 120 mm. Aperture framing/beading shall be applied to achieve necessary thickness of 150 mm locally. Build up is not required for floors with thicknesses equal to or greater than 150 mm.

The metal pipe shall be positioned at the centre of the core hole leaving an annular gap no less than 5 mm. The maximum allowed annular gap is 25 mm. The gap shall be filled with Hilti CP 606 to a minimum depth of 30 mm and backed with PE backing rod (BR) or mineral stone/rock wool.

The FRL assigned applies to the installation configuration where PVC pipe section or Hilti cast in collar CP680/CP680P/CP680PX/CP680M casted in floor remains in the concrete floor.

PEF backing rod can be open or closed, sealant can be filled full depth of the wall so that the use of backing rod can be avoided.

The metal pipe shall be copper, brass and ferrous (steel and iron) pipes specified in the assessment table, stainless and galvanised pipe is also included.

Pipe insulation can either be mineral stone/rock wool with greater density and thickness, or Bradford Fibertex 450.

Mineral stone/rock wool insulation must be overlapped by a minimum length equivalent to the pipe diameter. Such overlap is not required for pre-formed mineral stone/rock wool section.

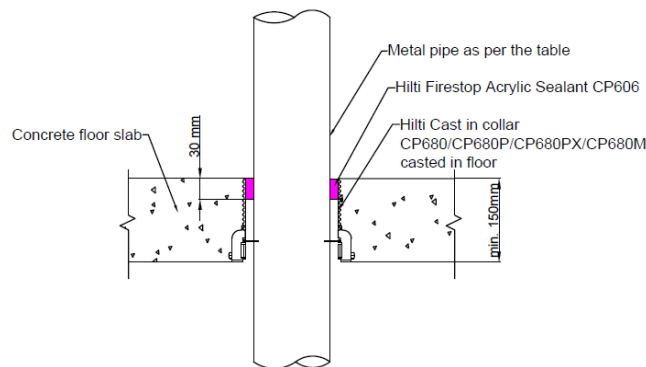

Figure 25 Side view – 120 mins FRL rigid floor with cast-in collar in concrete slab detail

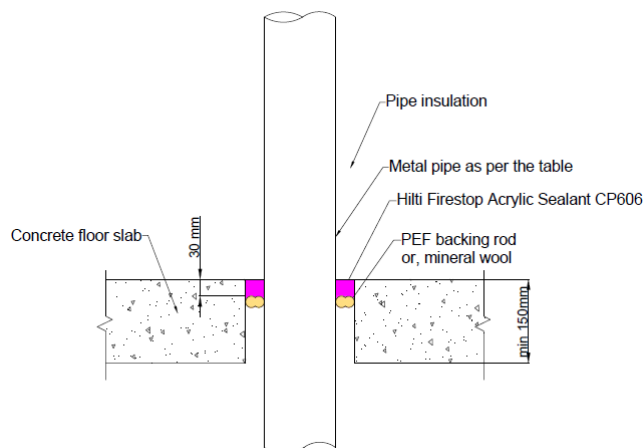

Figure 26 Side view – 120 mins FRL rigid floor system with sealant only

Table 17 Assessment summary of metal pipe configuration as per Figure 26

Metal pipe material	Separating element, t _A	Build up detail	Pipe nominal diameter, DN (mm)	Minimum pipe wall thickness (mm)	Annular gap (mm)	Sealant depth (mm)	Backing configuration	Pipe insulation configuration	FRL
Copper, ferrous or brass	Rigid floor, min 150 mm	None	Up to 65	0.91	5-25	30	PEF backing rod, CF 116, CF-F 750 GV, CF 126 or mineral rock wool	None	-/240/-*
Copper, ferrous (steel and iron)			80-100	1.22					-/120/-
			125	1.42					
			150	1.63					

*The FRL of the penetration is limited by that of the separating element. If the separating element has a stated FRL of -/120/120, then the fire resistance period (FRP) of the penetration is also limited to 120 minutes with respect to integrity and insulation.

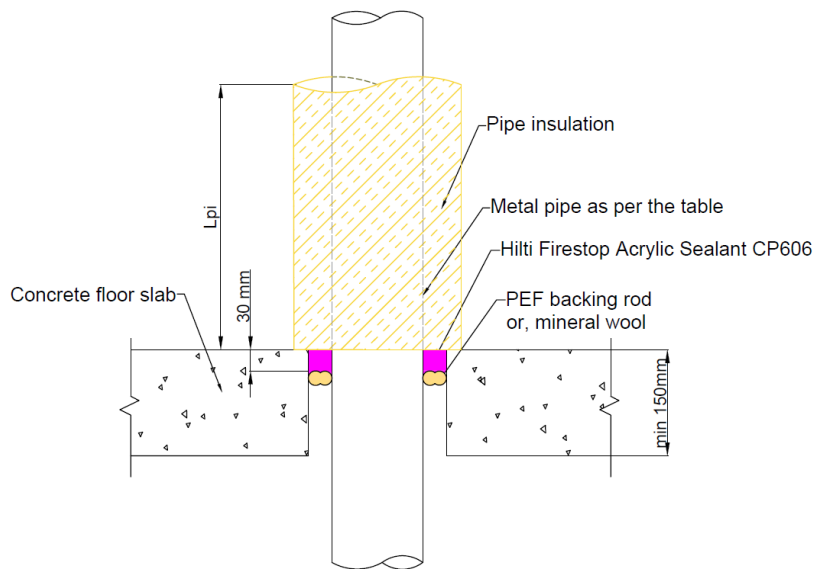

Figure 27 Side view – 120 mins FRL rigid floor system with or without mineral stone wool

Table 18 Assessment summary of metal pipe configuration as per Figure 19

Metal pipe material	Separating element, t _A	Build up detail	Pipe nominal diameter, DN (mm)	Mini pipe wall thickness (mm)	Annular gap (mm)	Sealant depth (mm)	Backing configuration	Pipe insulation config	Insulation length	FRL
Copper, ferrous or brass	Rigid floor, min 150 mm PVC pipe section/ Hilti cast in collar	None	Up to 15	0.91	5-25	30	PEF backing rod, CF 116, CF-F 750 GV, CF 126 or mineral rock wool	mineral rock wool insulation, or preformed mineral rock wool insulation, installed on each side of the wall	200	- /240/120 *
			20-32	0.91					300	
			40-65	0.91					400	
			80-100	1.22					500	
			125	1.42					600	
Copper, ferrous (steel and iron)	P/ PX/M series casted in floor can remain in the concrete floor"		150	1.63						- /120/120

*The FRL of the penetration is limited by that of the separating element. If the separating element has a stated FRL of -/120/120, then the fire resistance period (FRP) of the penetration is also limited to 120 minutes with respect to integrity and insulation.

6 DIRECT FIELD OF APPLICATION

This assessment applies to penetrations in walls and floors exposed to fire from either side.

7 REQUIREMENTS

This report details the methods of construction, test conditions and assessed results that would have been expected had the specific elements of construction described herein been tested in accordance with AS 1530.4:2005.

The supporting construction shall be capable of providing effective support of the proposed construction for the required fire resistance period (FRL).

Any further variations with respect to size, constructional details, loads, stresses, edge or end conditions, other than those identified in this report, may invalidate the conclusions drawn in this report.

8 VALIDITY

This assessment report does not provide an endorsement by Warringtonfire Aus Pty Ltd of the actual products supplied.

The conclusions of this assessment may be used to directly assess the fire resistance performance under such conditions, but it should be recognised that a single test method will not provide a full assessment of the fire hazard under all fire conditions.

Because of the nature of fire resistance testing, and the consequent difficulty in quantifying the uncertainty of measurement, it is not possible to provide a stated degree of accuracy. The inherent variability in test procedures, materials and methods of construction, and installation may lead to variations in performance between elements of similar construction.

The assessment can therefore only relate only to the actual prototype test specimens, testing conditions and methodology described in the supporting data, and does not imply any performance abilities of constructions of subsequent manufacture.

This assessment is based on information and experience available at the time of preparation. The published procedures for the conduct of tests and the assessment of test results are the subject of constant review and improvement and it is recommended that this report be reviewed on or, before, the stated expiry date.

The information contained in this report shall not be used for the assessment of variations other than those stated in the conclusions above. The assessment is valid provided no modifications are made to the systems detailed in this report. All details of construction should be consistent with the requirements stated in the relevant test reports and all referenced documents.

9 AUTHORITY

APPLICANT UNDERTAKINGS AND CONDITIONS OF USE

By using this report as evidence of compliance or performance, the applicant(s) confirms that:

to their knowledge the component or element of structure, which is the subject of this assessment, has not been subjected to a fire test to the Standard against which this assessment is being made, and they agree to withdraw this assessment from circulation should the component or element of structure be the subject of a fire test by a test authority in accordance with the Standard against which this assessment is being made and the results are not in agreement with this assessment, and they are not aware of any information that could adversely affect the conclusions of this assessment and if they subsequently become aware of any such information, agree to ask the assessing authority to withdraw the assessment.

GENERAL CONDITIONS OF USE

This report may only be reproduced in full without modifications by the report sponsor. Copies, extracts or abridgments of this report in any form shall not be published by other organisations or individuals without the permission of Warringtonfire Aus Pty Ltd.